

NOTE: WATER METER SHALL NOT BE LOCATED IN AREAS SUBJECT TO VEHICULAR TRAFFIC

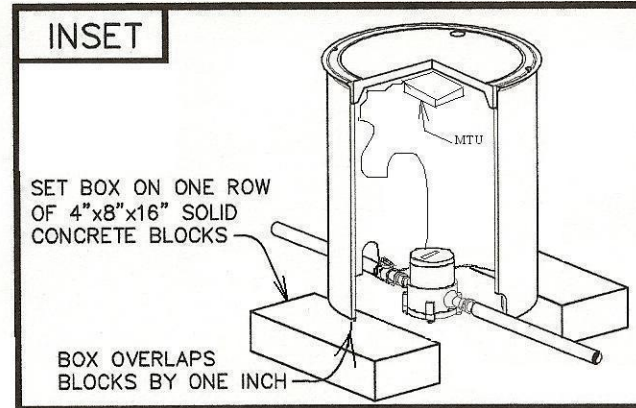

ATLANTIC CITY
MUNICIPAL UTILITIES AUTHORITY

401 NORTH VIRGINIA AVENUE
PO BOX 117
ATLANIC CITY, NJ 08404-0117

DOMESTIC METER PIT DETAIL

M MEGELLA 2008
APPROVED BY
DESIGN GUIDE
REVISED 07/30/08